

HS-2500EL Technical Data Sheet

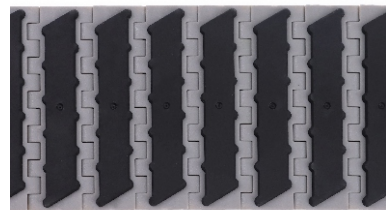
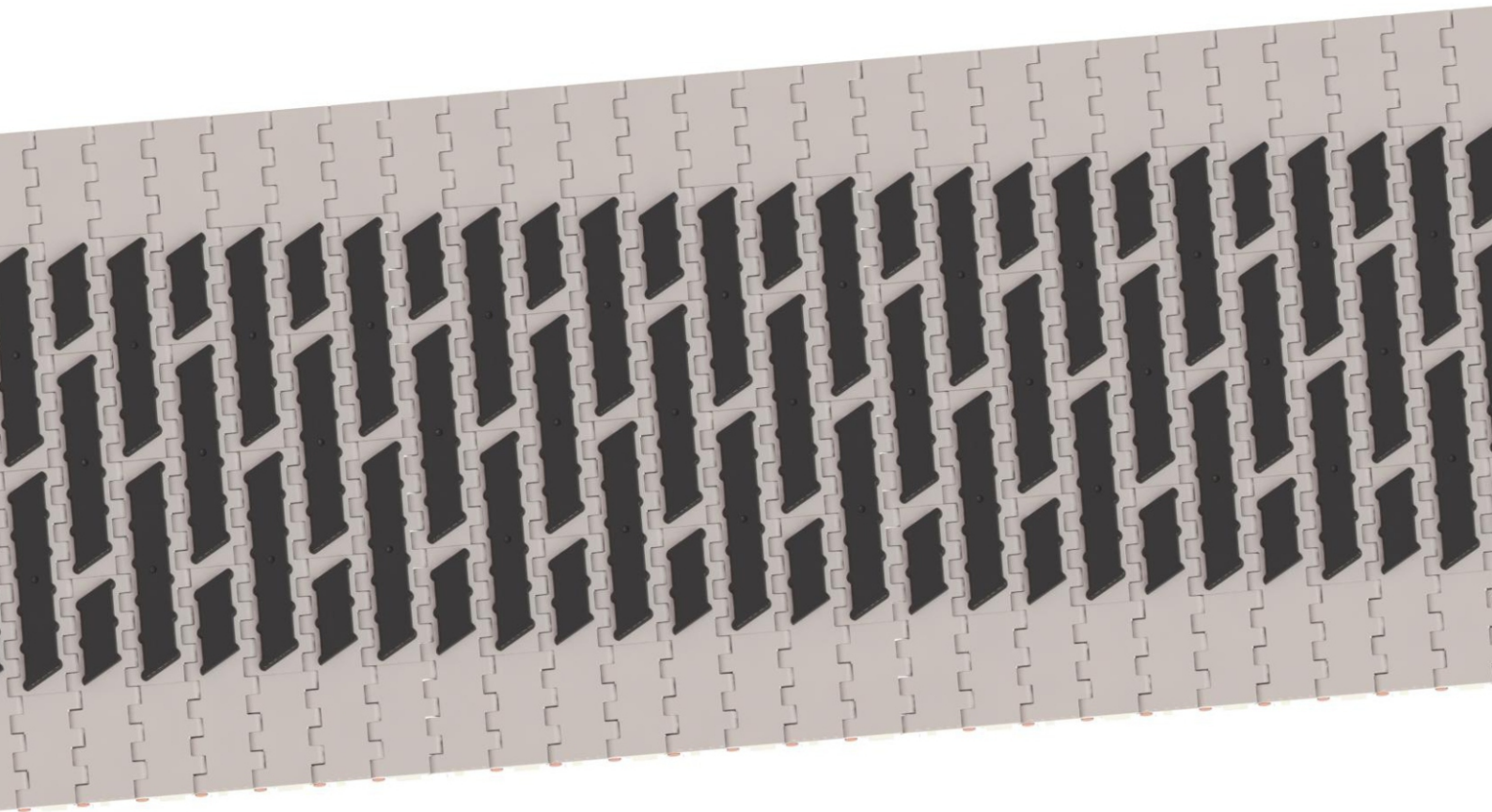

<p>Pitch: 25.4mm Minimum Width: 100mm Open Area: 0% Approved: FDA Rod: Ø 4.9mm Flight: Yes Side Guard: No Curve : No</p>	
---	--

Data

Belt Material	Belt Strength			Temperature		Belt Weight
	Straight		Curve	°C (min.)	°C (max.)	(Kg/M ²)
	Kg/M(BW)	N/M(BW)				
Polypropylene	1846	18460	--	1	70	8.7

BW – Belt Width

Color Table

Polypropylene					Polyethylene					Acetal					Nylon				
W	G	N	DB	B	W	G	N	DB	B	W	G	N	DB	B	W	G	N	DB	B
●	●			●															

W-White, G-Gray, N-Nature, DB-Dark brown, B-Blue (For more information of belt color, pls consult our sales team)

Friction Table

Belt Material	Friction Wear strips & Products							
	UHMW	HDPE	Steel	Glass	SUS	Plastic	Cardboard	Aluminum
Polypropylene	0.32	0.24	0.15	0.09	0.13	0.08	0.15	0.25
Polyethylene	0.13	0.11	0.26	0.19	0.31	0.16	0.21	0.41
Acetal	0.11	0.09	0.27	0.16	0.26	0.15	0.19	0.28
Nylon	0.18	0.13	0.25	0.16	0.26	0.16	0.19	0.27

SUS – Stainless Steel

Equivalent type with other Brand

Brand Name	Intralox	Habasit	UNI	Rexnord	MCC	ScanBelt
Series & Type	--	M2520 GripTop	--	--	--	--

The above content is only for reference.

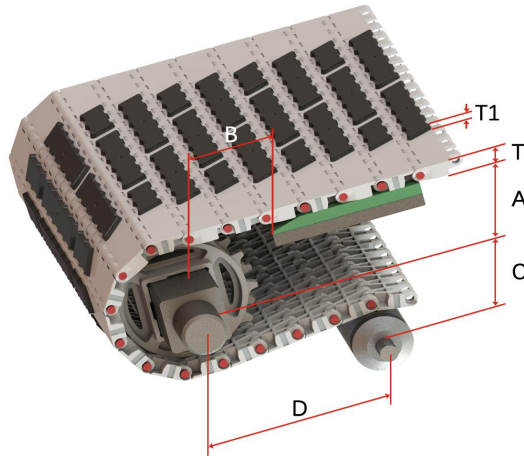

Conveyor Frame Dimensions

Unit : mm

No. Teeth	A (Min.)	B (Min.)	C (Max.)	D (Min.)	T	T1
8-2R	27.8	42.8	26.8	200	10	4
10-2R	36.25	51.25	35.25	200		
12-2R	44.5	59.5	43.5	200		
15-2R	57	72	56	200		
16-2R	60.57	75.75	59.75	200		
18-2R	69.25	84.25	68.25	200		
20-2R / 20-2R-Split	77.25	92.25	76.25	200		

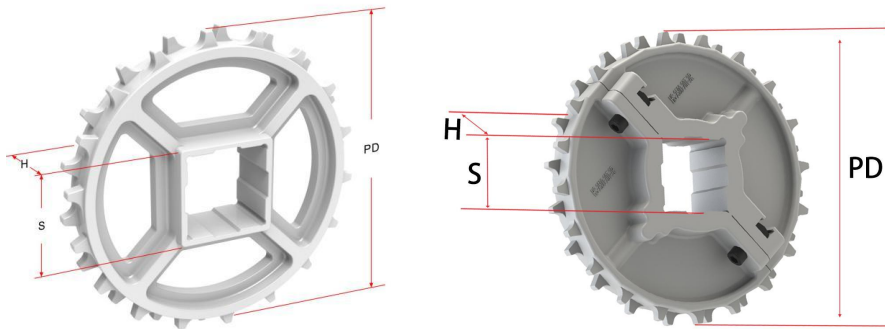

Sprocket Dimensions

Unit: mm

No. Teeth	PD	OD	S	D	H	K
8-2R	66.37	65.6	--	25.4/30	30	8X8
10-2R	82.20	82.5	25.4/38.1/40	25.4/30/31.75	30	8X8
12-2R	98.14	99	38.1/40	25/25.4/30/32	20	8X8
15-2R	122.17	124	38.1/40	25.4/30/35	20	8X8
16-2R	130.20	131.5	38.1/40	30	20	8X8
18-2R	146.27	148.5	38.1/40/60	25.4/30/31.75	20	8X8
20-2R	162.37	164.5	38.1/40/60/70	--	30	--
20-2R-Split	162.37	164.5	38.1/40/60	--	40	--